

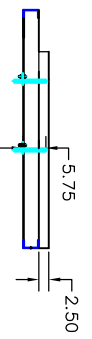

REVISIONS				
ZONE	REV	DESCRIPTION	DATE	APPROVED

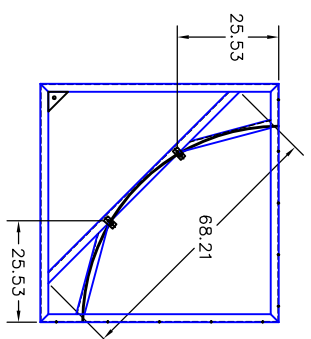
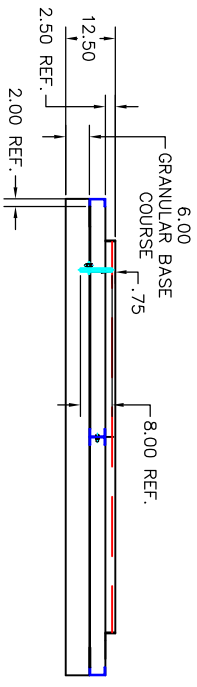
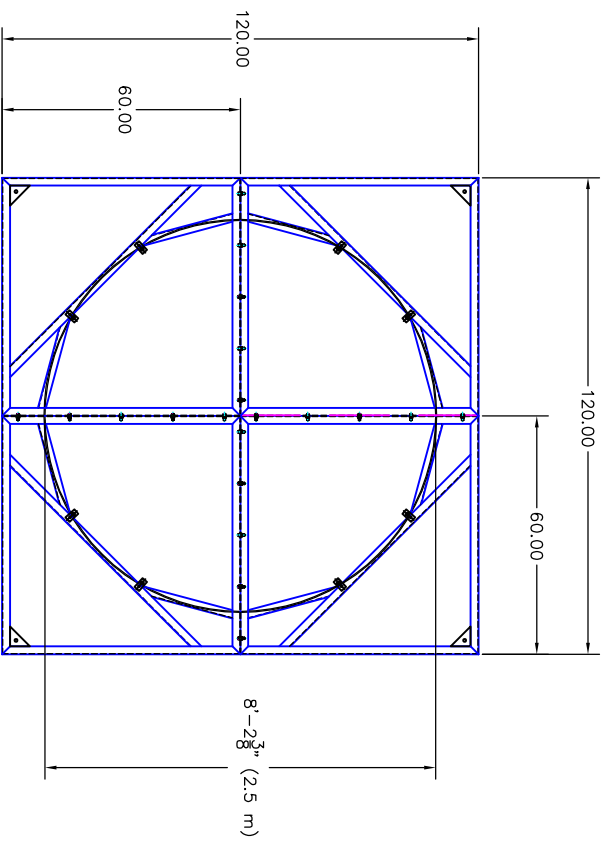

FOUR UNITS AS SHOWN TO MAKE ONE THROWING RING

This drawing contains information proprietary to UCS Inc., any reproduction disclosure or use of this drawing is EXPRESSLY PROHIBITED unless agreed in writing by UCS Inc.



UCSS
UNLESS OTHERWISE SPECIFIED
DIMENSIONS ARE IN INCHES
LINEAR TOL: $\pm 1/16"$
ANGULAR TOL: $\pm 1/2"$

800-526-4856 www.ucsspirit.com

511 HOFFMAN RD
LINCOLTON, NC, 28092

CONTRACT NO.	TITLE
APPROVALS	UCS POUR-IN-PLACE THROWING DISCUS RING
DATE	DATE
DRAWN	ENGINEER
CHECKED	DATE
SCALE	SCALE
SIZE	FILE
REV	REV
PROTECTIVE FINISH	PROTECTIVE FINISH

SHEET 1 OF 1