

This drawing contains information proprietary to UCS Inc., any reproduction disclosure or use of this drawing is EXPRESSLY PROHIBITED unless agreed in writing by UCS Inc.

ZONE	REV	DESCRIPTION	REASONS	DATE	APPROVED

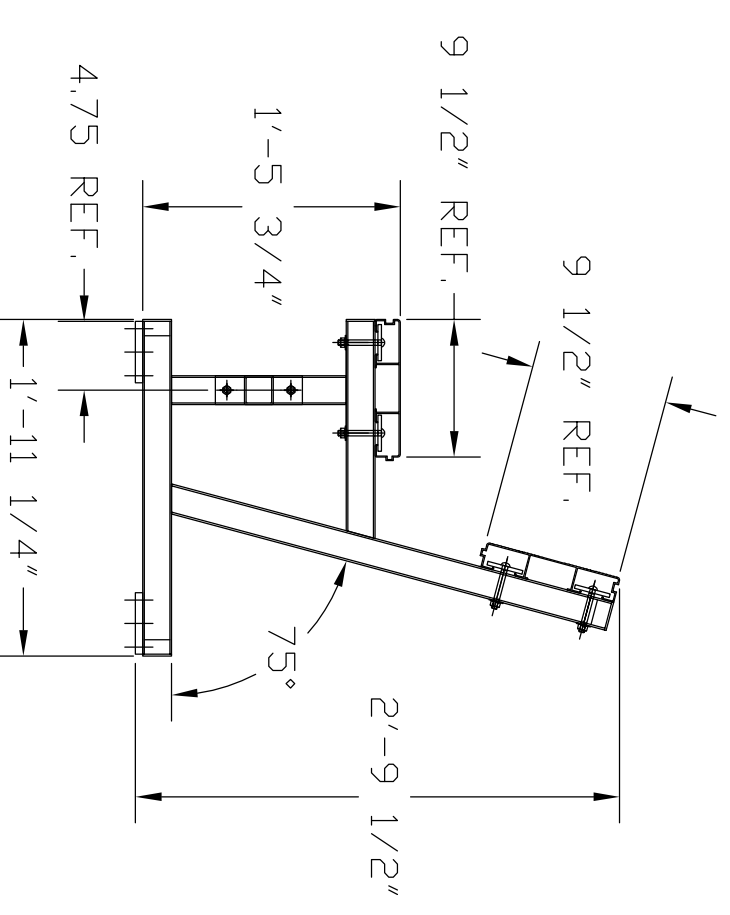
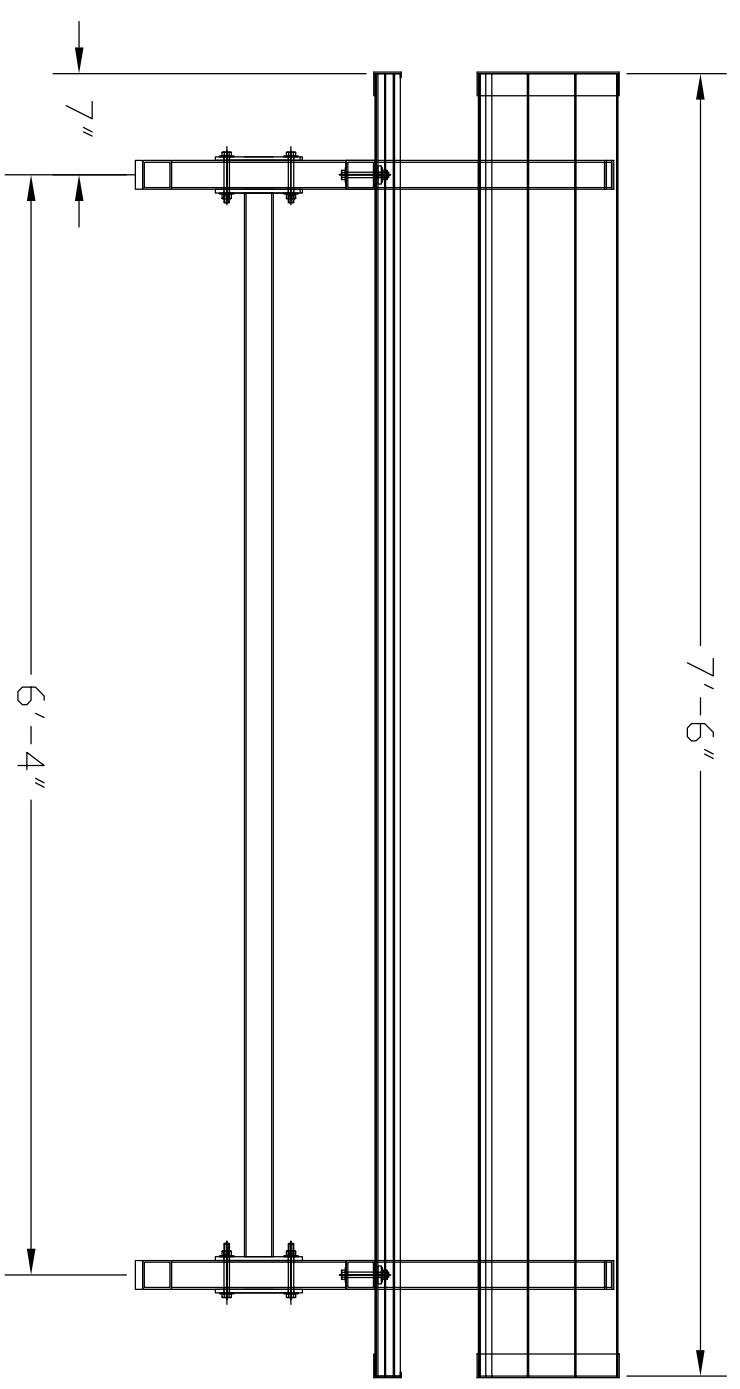

800-526-4856 www.ucsspirit.com

5111 HOFFMAN RD. LINCOLN, N.C. 28092

UCS
 BENCH 7.5' WITH BACK REST

UNLESS OTHERWISE SPECIFIED	JOB NO.	DATE		TITLE	SIZE	FILE	DWG NO.	REV.
DIMENSIONS ARE IN INCHES					D			
LINEAR TOL: ±.062	APPROVALS							
ANGULAR TOL: ± 1/2"	DRAWN D. Keaton		5-6-05				525-1207	
1 PLACE ±.031	CHECKED							
2 PLACE ±.031	ENGINEER							
3 PLACE ±.010	CHECKED							
MATERIAL: ALUMINIUM 6063-T6								
PROTECTIVE FINISH:								

8 7 6 5 4 3 2 1

A B C D

A B C D