

This drawing contains information proprietary to UCS Inc., any reproduction disclosure or use of this drawing is EXPRESSLY PROHIBITED unless agreed in writing by UCS Inc.

REV	DESCRIPTION	DATE	APPROVED

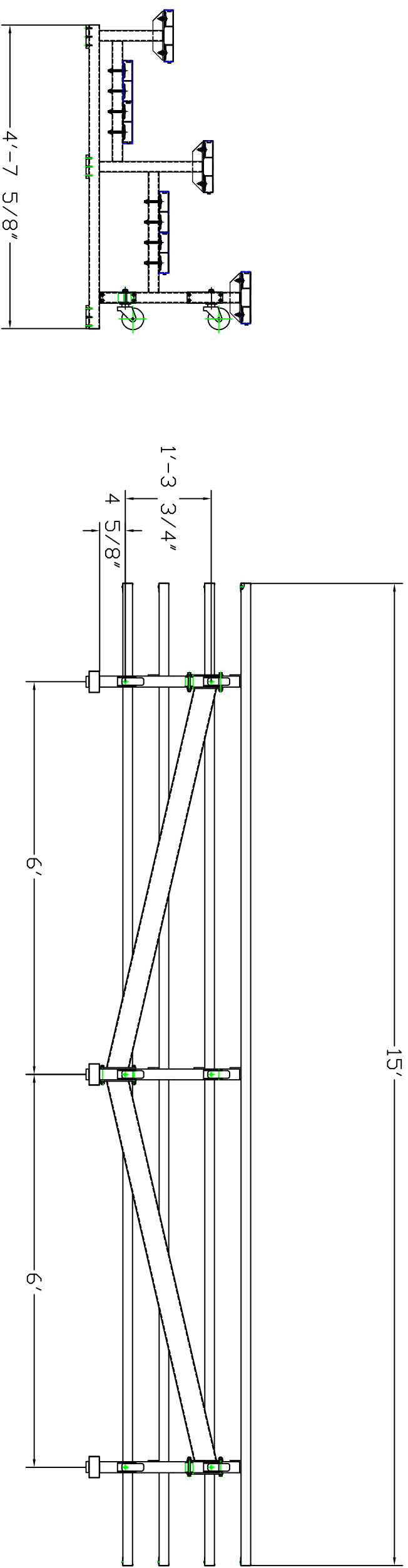

UNLESS OTHERWISE SPECIFIED DIMENSIONS ARE IN INCHES		CONTRACT NO.		UCS		511 HOFFMAN RD. LINCOLNTON, N.C. 28092	
DECIMAL TOL: 2 PLACES ±.03	ANGULAR TOL: ± 1/2°	APPROVALS	DATE	BLEACHER TILT & ROLL SERIES 3 ROWS 15' LONG			
3 PLACES ±.010		DRAWN D. Keaton	11-17-06				
MATL: ALUMINUM		CHECKED					
PROTECTIVE FINISH:		CHECKED		SIZE	FILE	DWG NO.	REV.
				SCALE NONE		525-8315	-

